

Crane lifting eye optional  
Article number: 911012005

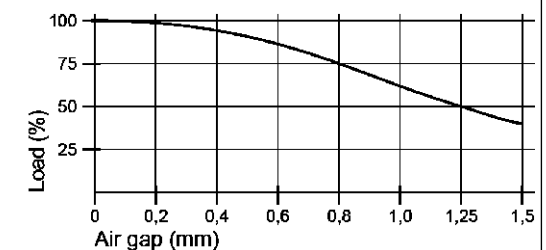
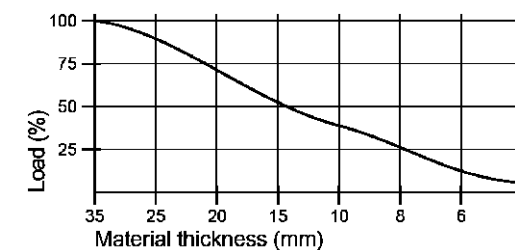
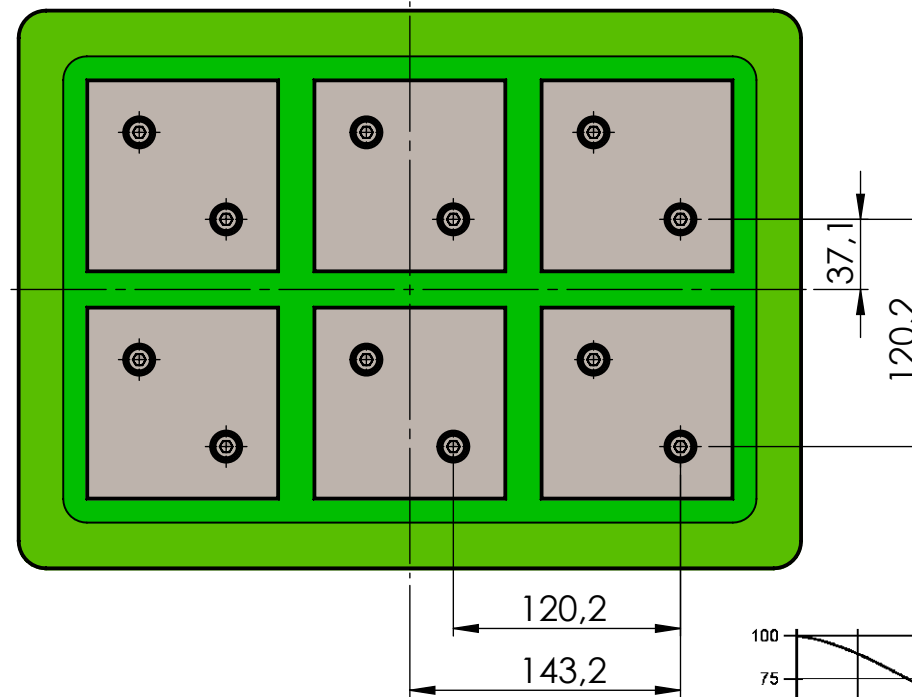
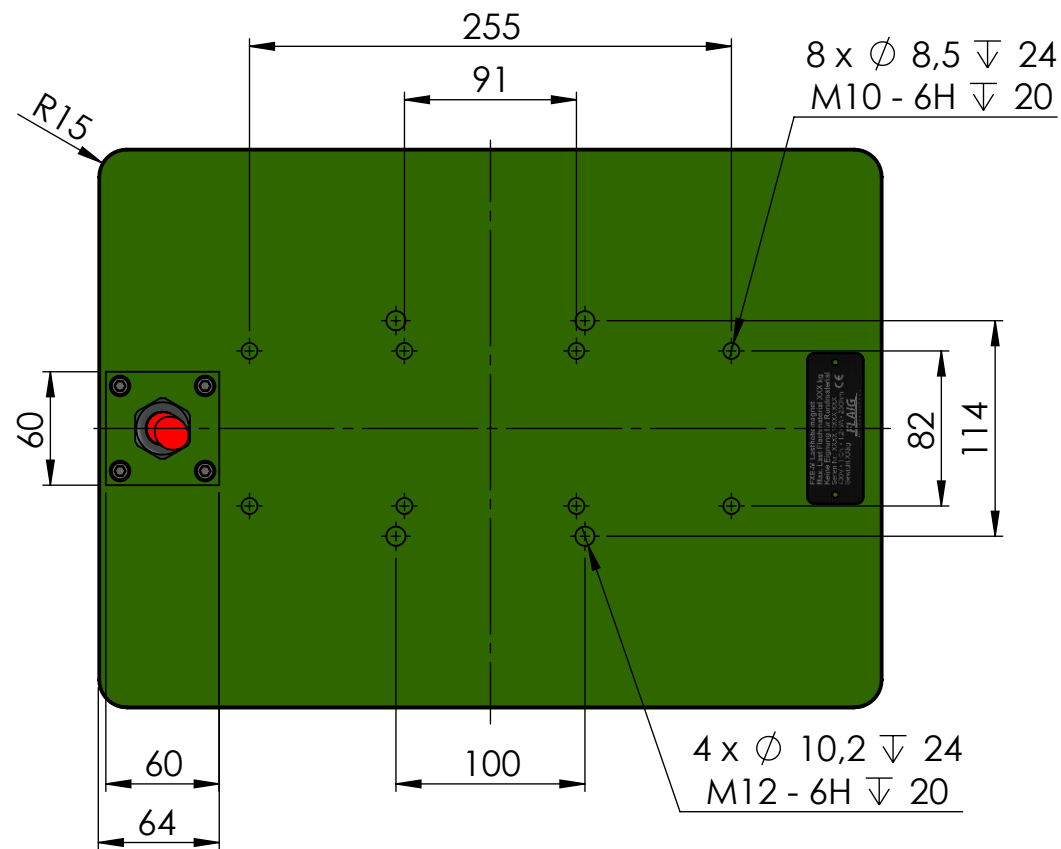
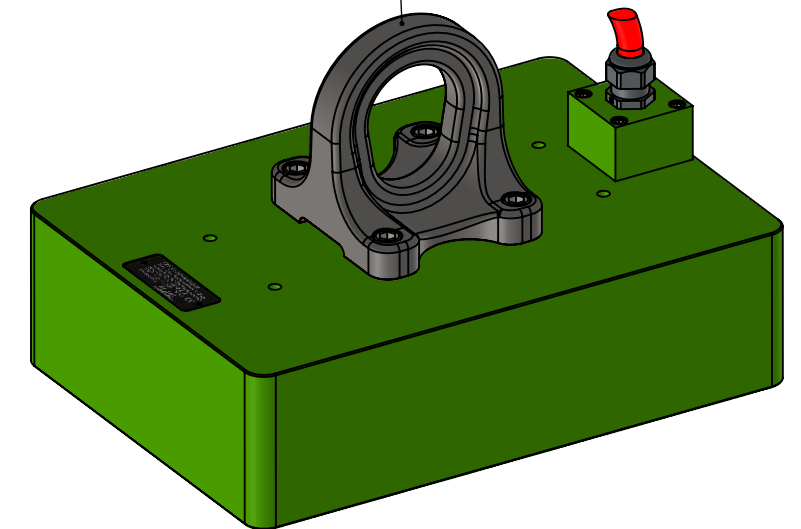

Specification FXE-M 2400-100	
Nominative Force: 87kN	lifting capacity EN 13155/WLL
Materialthickness >35mm (100%)	2400kg
16,9kVA	
U: 380-480V Pulse	Protection Type IP 65
R: 1,6Ω	Protection category SK I

Schutzvermerk nach DIN ISO 16016 beachten! Nachdruck nur mit unserer Genehmigung!			
All rights reserved according to DIN ISO 16016! Reprint with our permission only!			
rev.	change	date	name

3,2	-0,05 -0,2	tolerance	material:
		ISO 7168 M	weight: 106.30
date	name	drawing no.:	
drawn 19.08.2022	TW	0014134	
edit 19.08.2022		description: <b>FXE M 2400-100</b>	
appr. 19.08.2022	TW	part no.:	
 www.flraig-te.de		10612403	
		sheet 1 / 1	
scale: 1:4		Status: Freigegeben	

sheet 1 / 1	
A3	